



SEPTEMBER 2010 - MARCH 2011



HEAT RECOVERY UNITS

Selection & Price List

CONTENTS

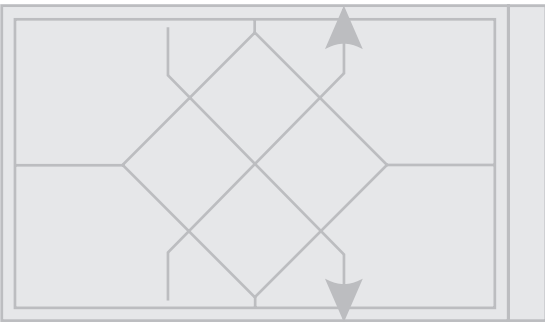

5

ORDERING INFORMATION

Description....



6

NEVADA EXTERNAL DOUBLE DECKED HEAT RECOVERY UNIT

Description....

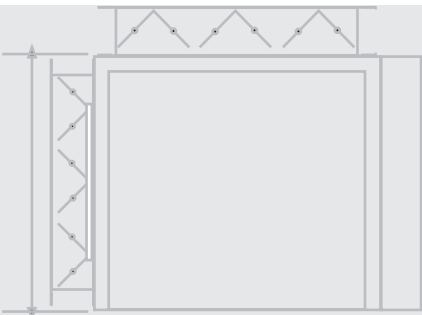

8

NEVADA INTERNAL DOUBLE DECKED HEAT RECOVERY UNIT

Description....

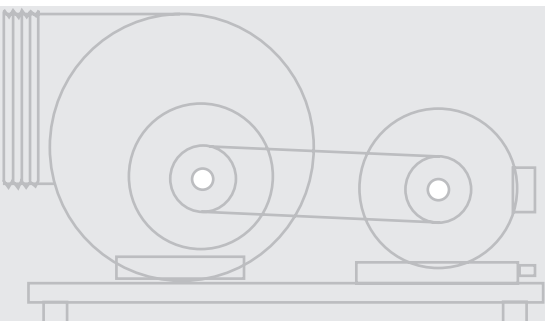

10

NEVADA EXTERNAL SIDE BY SIDE HEAT RECOVERY UNIT

Description....

12 NEVADA INTERNAL SIDE BY SIDE HEAT RECOVERY UNIT

Description....

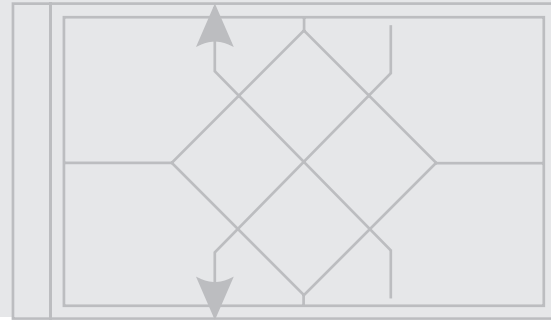

14 ELECTRIC HEATER BATTERY PRICE LIST

Description....



15 CONTROLS PRICE LIST

Description....

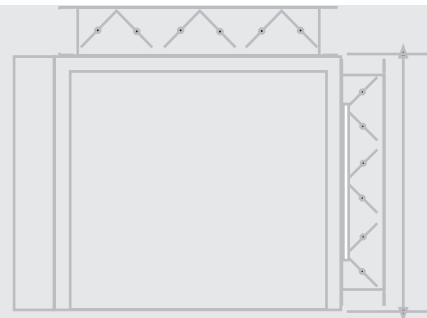

17 ACCESSORIES

Description....

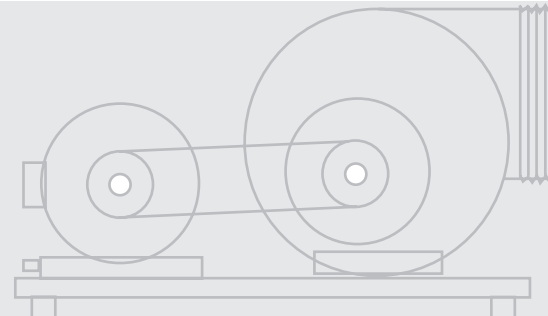

INTRODUCTION

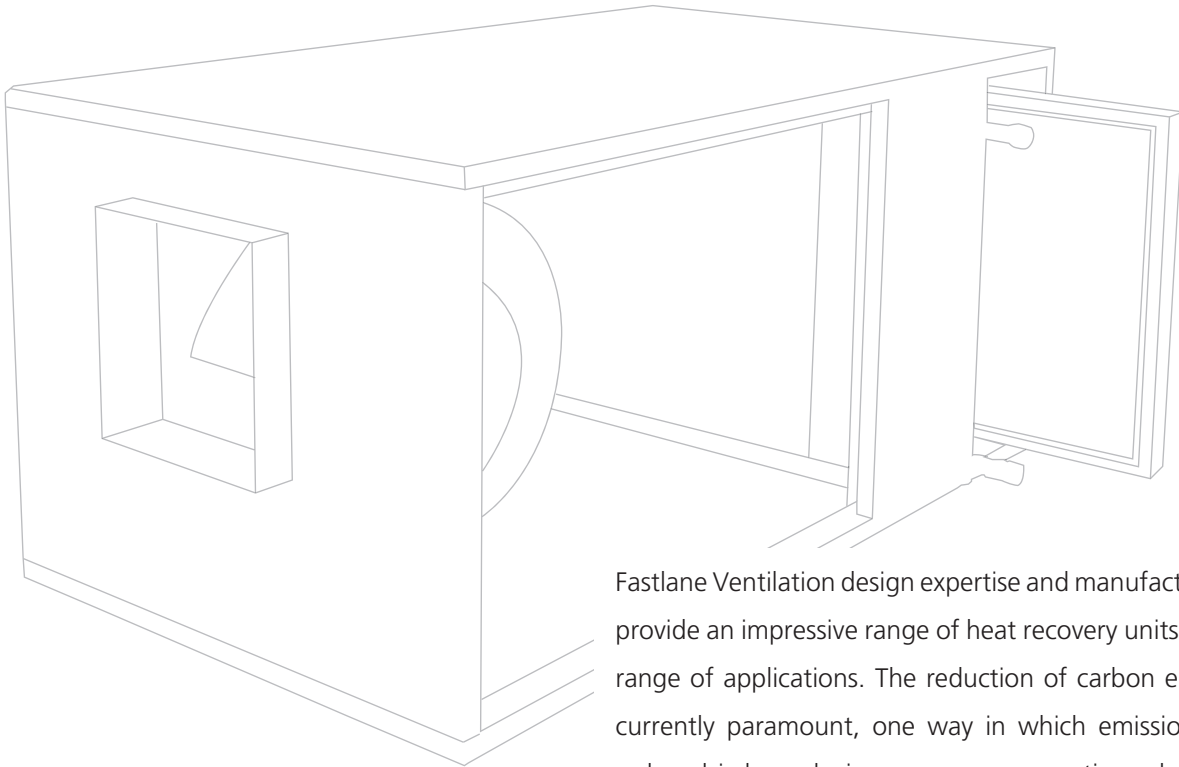

Fastlane Ventilation design expertise and manufacturing skills provide an impressive range of heat recovery units for a wide range of applications. The reduction of carbon emissions is currently paramount, one way in which emissions can be reduced is by reducing energy consumption when heating and cooling buildings, by incorporating heat recovery equipment. Instead of extracting the stale air and sending heated air to atmosphere energy recovery devices can be incorporated into the extract plant to recover a large proportion of the otherwise wasted heat which can then be transferred to the supply air stream.

At Fastlane, our expertise is built around the accumulated knowledge of HVAC engineers, and supported by the extensive design and test facilities of our larger parent, the ELTA Group. Fastlane therefore offer quality products, with reliable and accurate data, which can be installed with confidence to meet your heat recovery requirements.

Our data tables offer a quick and easy method of selection, our extensive stock of components allow us to offer very short lead times on most orders.



ORDERING

1

Please ensure you have the following information:

- Type of heater:
 - Circular
 - Duct Mounted
 - Stab-In
- Air volume (m³/s)
- kW loading
- Electrical supply – 230/1Ph or 400/3Ph
- Number of steps
- Duct Size – width x height or diameter (mm)
- Vertical airflow if required
- Any special requirements

2

Contact the team at Fastlane:

T: + 44 (0) 1892 836099

F: + 44 (0) 1892 836448

E: sales@fastlaneventilation.co.uk

IMPORTANT

- A run on timer must be incorporated into the control system to allow the fan to run on after the heater has been switched off to dissipate any residual heat.
- Care must be taken when positioning the heater to prevent any damage or overheating of any other equipment in the system.
- It is the responsibility of the final installation or commissioning person on site to ensure that all safety control interlocks function correctly and to shut down systems or part systems as designed to do so, within several seconds of activation.

Technical Data

Maximum Leaving Air Temperature	40°C
Maximum Element Temperature	400°C
Minimum Air Velocity	2 m/s
Maximum Air Velocity	6 m/s
Voltage	230V/1Ph or 400V/3Ph
Three Phase Connection	Star connection 3 wire for step control or 4 wires for thyristor control
Electrical Testing	Flash tested at 1750 volts for 2 seconds
Insulation Test	1 Meg Ohm minimum

Dimensions & Price List

NEVADA EXTERNAL DOUBLE DECKED

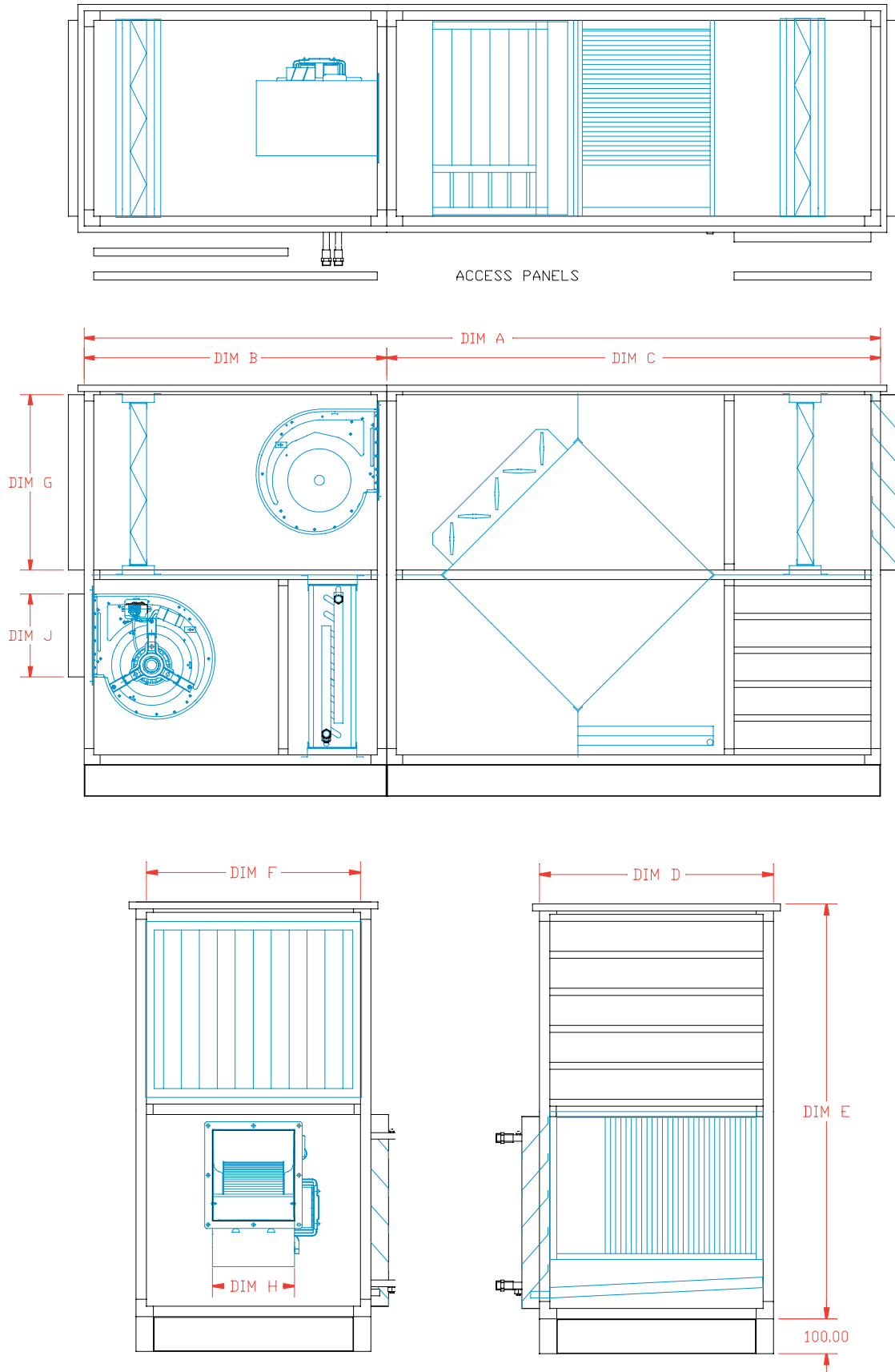

All Prices are Ex Works and Exclude VAT

Carriage at 5% of Order Value

HEAT RECOVERY UNIT

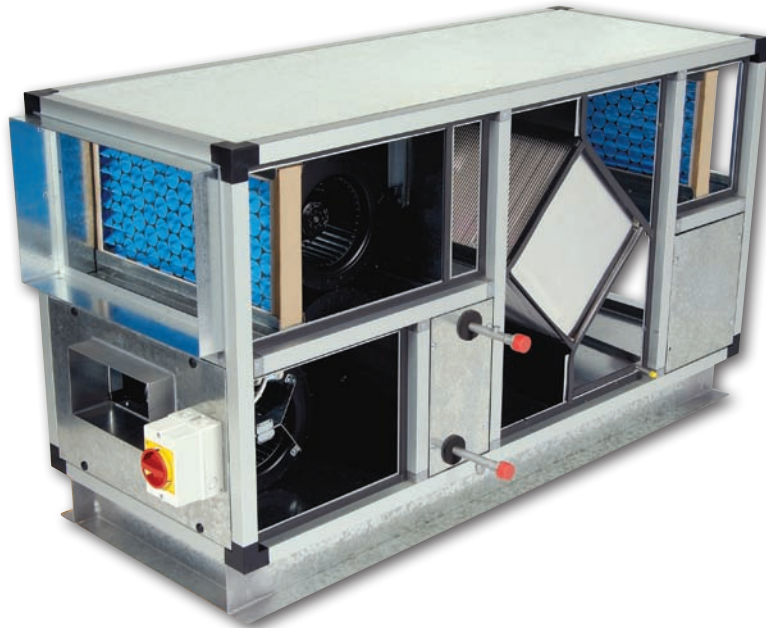

Dimensions

Product Code	DIM A	DIM B	DIM C	DIM D	DIM E	DIM F	DIM G	DIM H	DIM J	Weight kg
NP10 DD EHR	2250	850	1400	550	690	490	300	225	125	
NP20 DD EHR	2250	850	1400	675	830	605	370	275	210	
NP20HP DD EHR	2350	950	1400	675	830	605	370	260	235	
NP30 DD EHR	2500	950	1550	675	1190	605	550	235	260	
NP30HP DD EHR	2500	950	1550	675	1190	605	550	260	300	
NP40 DD EHR	2500	950	1550	750	1190	690	550	300	260	
NP40HP DD EHR	2550	1000	1550	750	1190	690	550	285	325	
NP50 DD EHR	2550	1000	1550	820	1190	760	550	325	285	

All dimensions are in mm.

Price List

Product Code	NPE EXT DD	NPHW EXT DD
NP10		
NP20		
NP20HP		
NP30		
NP30HP		
NP40		
NP40HP		
NP50		

All Prices are Ex Works and Exclude VAT

Carriage at 5% of Order Value

In accordance with our policy of constant product development we reserve the right to alter from published data without prior notice.

Dimensions & Price List

NEVADA INTERNAL DOUBLE DECKED

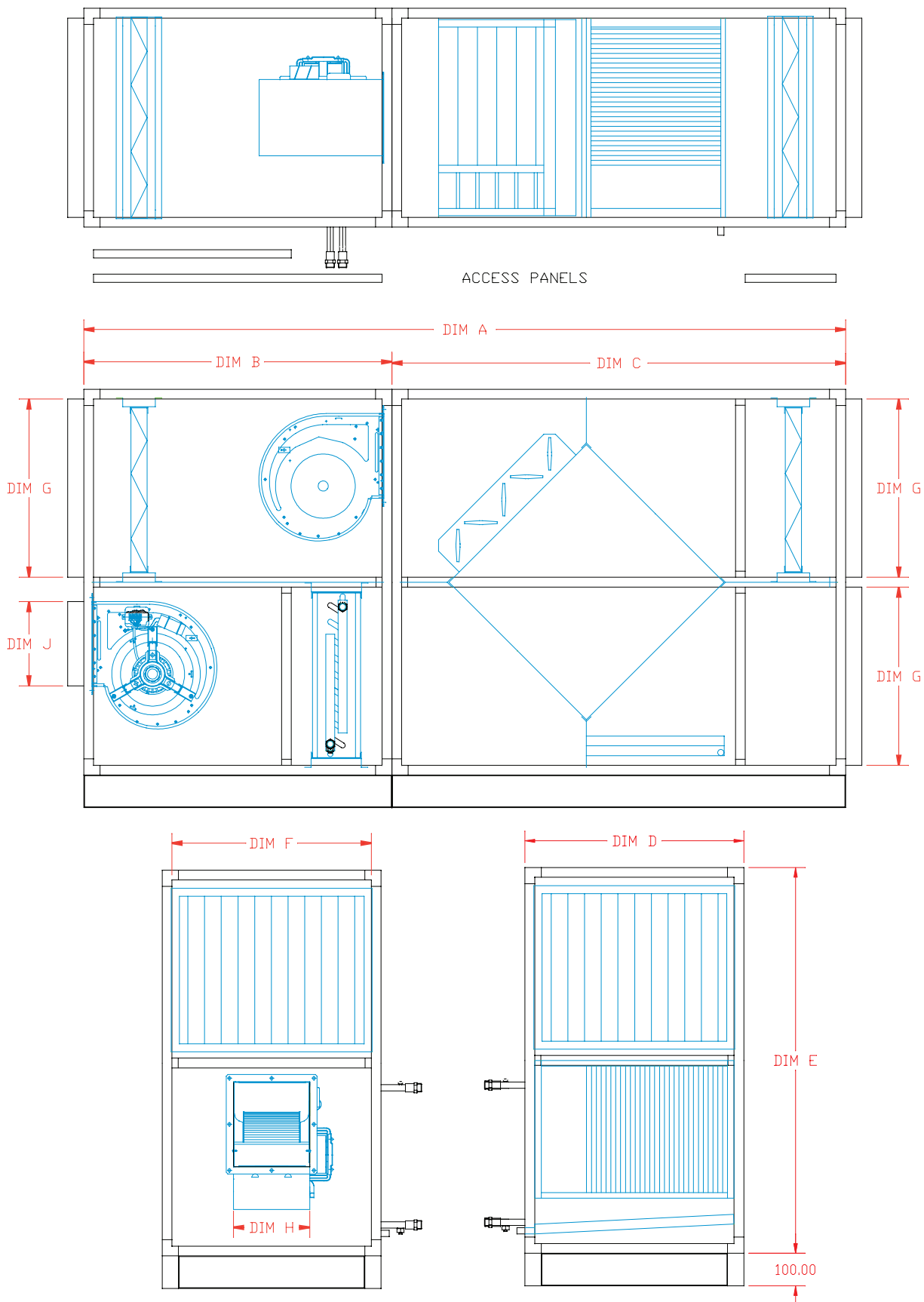

All Prices are Ex Works and Exclude VAT

Carriage at 5% of Order Value

HEAT RECOVERY UNIT

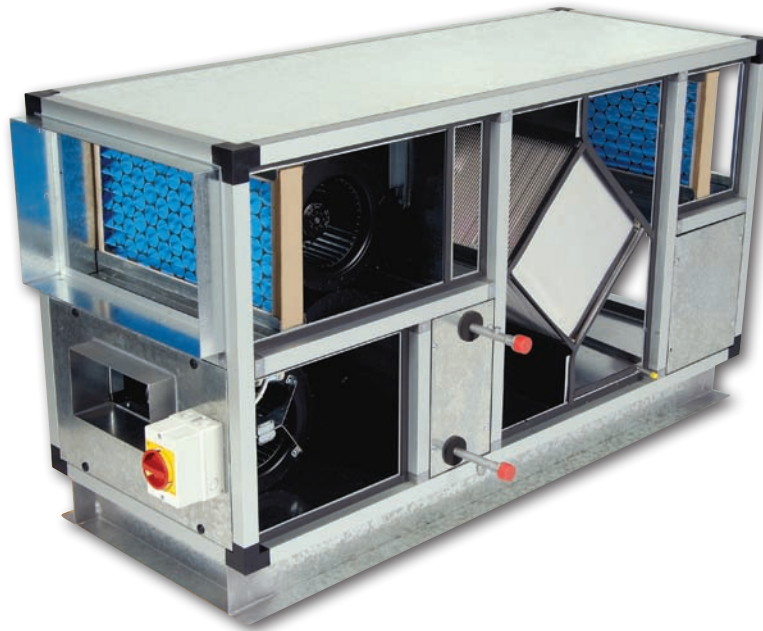

Dimensions

Product Code	DIM A	DIM B	DIM C	DIM D	DIM E	DIM F	DIM G	DIM H	DIM J	Weight kg
NP10 DD IHR	2100	580	1250	550	690	490	300	225	125	
NP20 DD IHR	2100	580	1250	675	830	605	370	275	210	
NP20HP DD IHR	2200	950	1250	675	830	605	370	260	235	
NP30 DD IHR	2350	950	1400	675	1190	605	550	235	260	
NP30HP DD IHR	2350	950	1400	675	1190	605	550	260	300	
NP40 DD IHR	2350	950	1400	750	1190	690	550	300	260	
NP40HP DD IHR	2400	1000	1400	750	1190	690	550	285	325	
NP50 DD IHR	2450	1000	1450	820	1190	760	550	325	285	

All dimensions are in mm.

Price List

Product Code	NPE INT DD	NPHW INT DD
NP10		
NP20		
NP20HP		
NP30		
NP30HP		
NP40		
NP40HP		
NP50		

All Prices are Ex Works and Exclude VAT

Carriage at 5% of Order Value

In accordance with our policy of constant product development we reserve the right to alter from published data without prior notice.

Dimensions & Price List

NEVADA EXTERNAL SIDE BY SIDE HEAT

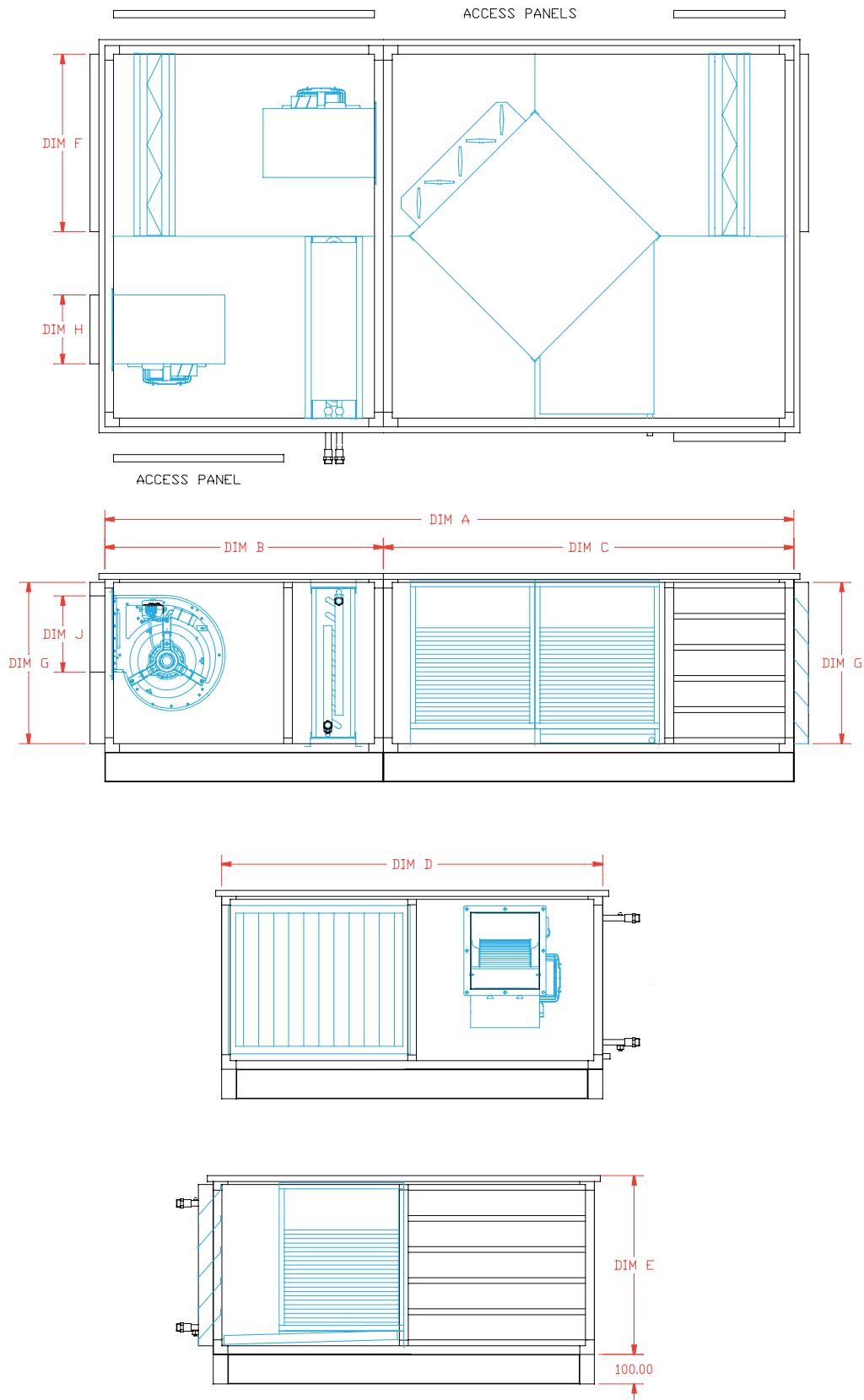

All Prices are Ex Works and Exclude VAT

Carriage at 5% of Order Value

RECOVERY UNIT



Dimensions

Product Code	DIM A	DIM B	DIM C	DIM D	DIM E	DIM F	DIM G	DIM H	DIM J	Weight kg
NP20 SBS IHR	2150	850	1300	1300	430	605	370	275	210	
NP20HP SBS HR	2350	950	1300	1300	430	605	370	260	235	
NP30 SBS IHR	2350	950	1300	1300	610	605	550	235	260	
NP30HP SBS IHR	2350	950	1300	1300	610	605	550	260	300	
NP40 SBS IHR	2550	950	1400	1450	610	680	550	300	260	
NP40HP SBS IHR	2600	1000	1400	1450	610	680	550	285	325	
NP50 SBS IHR	2600	1000	1450	1590	610	750	550	325	285	

All dimensions are in mm.

Price List

Product Code	NPE EXT SBS	NPHE EXT SBS
NP10		
NP20		
NP20HP		
NP30		
NP30HP		
NP40		
NP40HP		
NP50		

All Prices are Ex Works and Exclude VAT

Carriage at 5% of Order Value

In accordance with our policy of constant product development we reserve the right to alter from published data without prior notice.

Dimensions & Price List

NEVADA INTERNAL SIDE BY SIDE HEAT

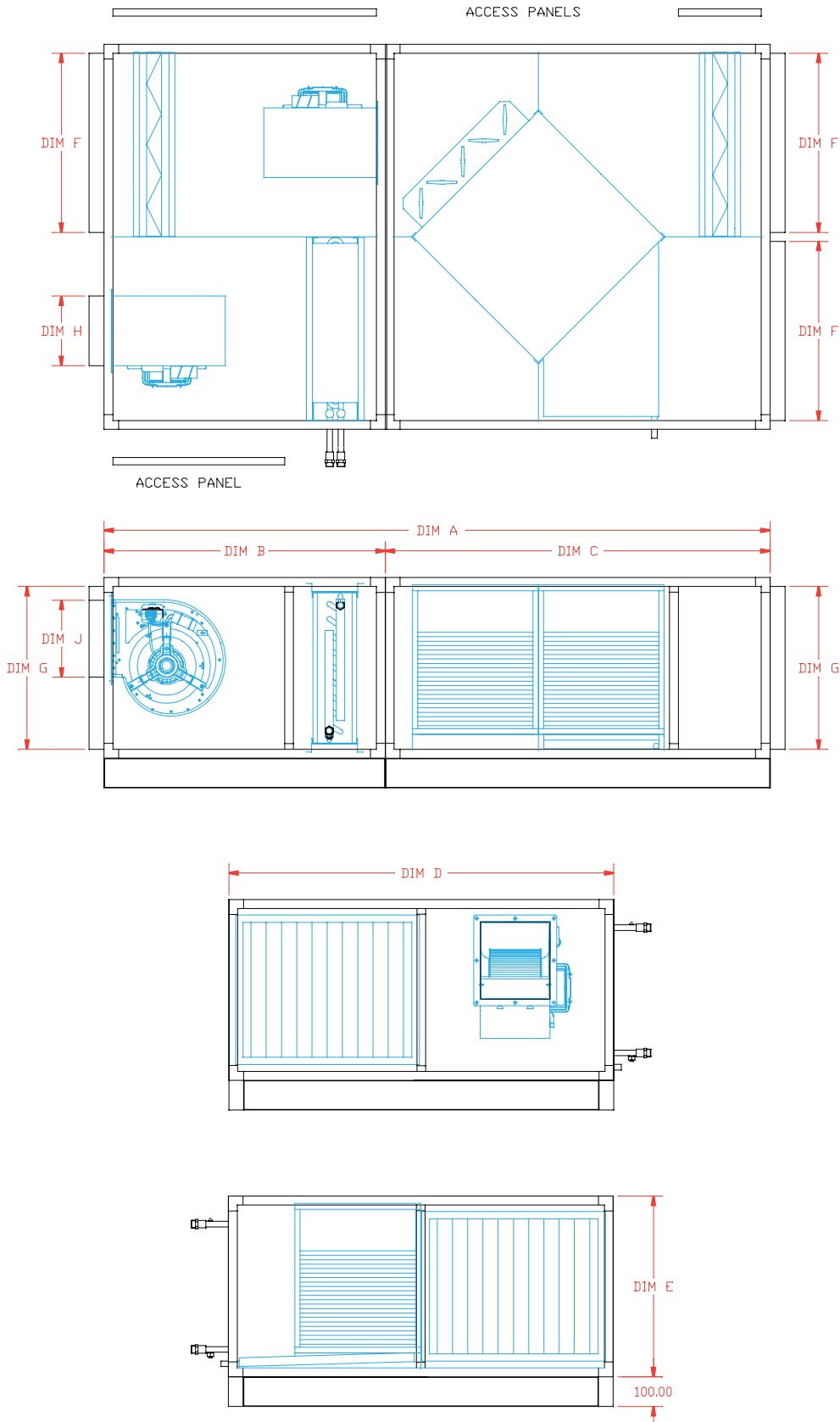

All Prices are Ex Works and Exclude VAT

Carriage at 5% of Order Value

RECOVERY UNIT



Dimensions

Product Code	DIM A	DIM B	DIM C	DIM D	DIM E	DIM F	DIM G	DIM H	DIM J	Weight kg
NP20 SBS IHR	2150	850	1300	1300	430	605	370	275	210	
NP20HP SBS IHR	2250	950	1300	1300	430	605	370	260	235	
NP30 SBS IHR	2250	950	1300	1300	610	605	550	235	260	
NP30HP SBS IHR	2250	950	1300	1300	610	605	550	260	300	
NP40 SBS IHR	2350	950	1400	1450	610	680	550	300	260	
NP40HP SBS IHR	2400	1000	1400	1450	610	680	550	285	325	
NP50 SBS IHR	2450	1000	1450	1590	610	750	550	325	285	

All dimensions are in mm.

Price List

Product Code	NPE INT SBS	NPHW INT SBS
NP10		
NP20		
NP20HP		
NP30		
NP30HP		
NP40		
NP40HP		
NP50		

All Prices are Ex Works and Exclude VAT

Carriage at 5% of Order Value

In accordance with our policy of constant product development we reserve the right to alter from published data without prior notice.

NEVADA Direct Drive Air Handling Unit ELECTRIC HEATER BATTERY PRICE LIST

Unit Size	Air Vol m ³ /sec	kW Rating	Single Phase Supply Steps (£)				Three Phase Supply Steps (£)		
			1	2	3	4	1	2	3
NWE 10 & NPE 10	All	3.00	86	97	86	97	-	-	-
	All	4.50	101	101	124	-	-	-	-
	All	6.00	124	124	124	-	-	-	-
	All	7.50	130	130	130	-	-	-	-
	0.28+	9.00	153	153	162	153	-	-	-
	0.31+	10.00	157	157	-	157	-	-	-
	0.33+	11.25	170	-	170	-	-	-	-
NWE 20 & NPE 20	All	3.00	83	83	89	100	-	-	-
	0.20+	4.50	99	103	99	-	-	-	-
	0.28+	6.00	116	116	127	116	-	-	-
	0.28+	7.50	137	140	137	-	-	-	-
	0.28+	9.00	148	148	148	156	-	-	-
	0.37+	12.00	181	181	186	181	186	-	-
	0.44+	13.50	-	-	-	-	197	-	197
0.50+	18.00	-	-	-	-	245	245	-	
NWE 30 & NPE 30	All	9.00	148	148	148	156	-	-	-
	All	12.00	181	181	186	181	186	203	-
	All	15.00	-	-	-	-	224	224	-
	All	18.00	-	-	-	-	245	245	-
	0.60+	22.50	-	-	-	-	294	-	-
	0.66+	27.00	-	-	-	-	343	343	343
NWE 40 & NPE 40	All	9.00	148	148	148	156	-	-	-
	All	12.00	158	158	158	181	158	158	-
	All	15.00	-	-	-	-	196	214	-
	All	18.00	-	-	-	-	211	245	211
	All	24.00	-	-	-	-	265	265	-
	0.85+	30.00	-	-	-	-	319	341	-
	0.98+	36.00	-	-	-	-	448	448	448
NWE 50 & NPE 50	0.75+	12.00	158	158	158	181	158	158	-
	0.75+	15.00	-	-	-	-	166	166	-
	0.75+	18.00	-	-	-	-	211	245	211
	0.75+	24.00	-	-	-	-	265	265	-
	0.80+	30.00	-	-	-	-	282	282	-
	0.98+	36.00	-	-	-	-	448	448	448
NWE 60 & NPE 60	All	12.00	128	128	158	128	158	158	-
	All	15.00	-	-	-	-	166	166	-
	All	18.00	-	-	-	-	174	174	211
	All	24.00	-	-	-	-	265	265	-
	0.81+	30.00	-	-	-	-	282	282	-
	1.06+	36.00	-	-	-	-	297	297	372
	1.33+	45.00	-	-	-	-	359	397	397
	1.33+	54.00	-	-	-	-	421	421	421

All Prices are Ex Works and Exclude VAT

Carriage at 5% of Order Value

NEVADA Direct Drive Air Handling Unit CONTROLS PRICE LIST

Single Phase

	1 Step £	2 Step £	3 Step £	4 Step £		Thyristor £
3 kW	589	-	-	-	4 kW	683
6 kW	604	604	618	632	6 kW	717
9 kW	629	621	618	632	10 kW	854
12 kW	-	627	649	639	16 kW	940

Three Phase

	1 Step £	2 Step £	3 Step £	4 Step £	5 Step £	6 Step £		Thyristor £
6 kW	607	618	637	-	-	-	6 kW	746
9 kW	620	637	640	-	-	-	10 kW	754
12 kW	630	637	640	659	-	-	18 kW	895
18 kW	675	665	670	-	-	-	28 kW	1,072
24 kW	714	698	719	713	-	-	36 kW	1,141
30 kW	-	742	719	759	814	842	50 kW	1,231
36 kW	-	780	747	759	-	842		
45 kW	-	-	825	-	884	-		
54 kW	-	854	895	832	-	936		
72 kW	-	-	1,101	1,189	-	1,195		
90 kW	-	-	-	-	-	1,326		

L.P.H.W

Modulating	£
Controller	747

Modulating	£
Size 10 Valve & Actuator	398
Size 20 Valve & Actuator	410
Size 30 Valve & Actuator	410
Size 40 Valve & Actuator	432
Size 50 Valve & Actuator	432
Size 60 Valve & Actuator	477

On / Off	£
Controller	664

On / Off	£
Size 10 Valve & Actuator	150
Size 20 Valve & Actuator	162
Size 30 Valve & Actuator	180
Size 40 Valve & Actuator	201
Size 50 Valve & Actuator	201
Size 60 Valve & Actuator	246

Ancillaries

	£
Filter Pressure Switch	20
Filter Dirty Indicator	10
Damper Motor Connections	15
Damper Motor 230v	63
Damper Motor 24v	63
7 Day Analogue Timeclock	54
7 Day Digital Timeclock	91
Extract Fan Control	43
Fire Alarm Relay Connections	44
L.P.H.W Only	
Frost Thermostat	44
Water Pipe Strap On Stat	24

All Prices are Ex Works and Exclude VAT

Carriage at 5% of Order Value



Price List

ACCESSORIES

NP10

Product	£
Atten 600mm Long	83
Atten 900mm Long	95
Atten 1200mm Long	114
Fan Outlet Flexi Connector	13
Spigot Flexi Connector	21
Spare Filter	12
Replacement Fan / Motor	168
Motor Isolator	53
Electronic Speed Controller	34
Auto Transformer Controller	164

NP30

Product	£
Atten 600mm Long	119
Atten 900mm Long	141
Atten 1200mm Long	171
Fan Outlet Flexi Connector	14
Spigot Flexi Connector	23
Spare Filter	15
Replacement Fan / Motor	184
Motor Isolator	53
Electronic Speed Controller	60
Auto Transformer Controller	188

NP20

Product	£
Atten 600mm Long	103
Atten 900mm Long	120
Atten 1200mm Long	144
Fan Outlet Flexi Connector	14
Spigot Flexi Connector	22
Spare Filter	14
Replacement Fan / Motor	178
Motor Isolator	53
Electronic Speed Controller	60
Auto Transformer Controller	164

NP30HP

Product	£
Atten 600mm Long	119
Atten 900mm Long	141
Atten 1200mm Long	171
Fan Outlet Flexi Connector	14
Spigot Flexi Connector	23
Spare Filter	15
Replacement Fan / Motor	197
Motor Isolator	53
Electronic Speed Controller	119
Auto Transformer Controller	188

NP20HP

Product	£
Atten 600mm Long	103
Atten 900mm Long	120
Atten 1200mm Long	144
Fan Outlet Flexi Connector	14
Spigot Flexi Connector	22
Spare Filter	14
Replacement Fan / Motor	184
Motor Isolator	53
Electronic Speed Controller	60
Auto Transformer Controller	188

NP40

Product	£
Atten 600mm Long	123
Atten 900mm Long	147
Atten 1200mm Long	178
Fan Outlet Flexi Connector	14
Spigot Flexi Connector	21
Spare Filter	19
Replacement Fan / Motor	197
Motor Isolator	53
Electronic Speed Controller	119
Auto Transformer Controller	188

All Prices are Ex Works and Exclude VAT

Carriage at 5% of Order Value

In accordance with our policy of constant product development we reserve the right to alter from published data without prior notice.



Unit 21/23, Eldon Way, Paddock Wood, Tonbridge, Kent, TN12 6BE. United Kingdom.

Tel: + 44 (0) 1892 836099 Fax: + 44 (0) 1892 836448

email: sales@fastlaneventilation.co.uk

www.fastlaneventilation.com



BS EN ISO 9001:2008
FMS14545

A member of the **ELTA**
GROUP LIMITED